

TLW™ Check Valve

The **TLW Check Valve** (Tapped Lug Wafer) was engineered for applications where exposed studs are not suitable. This non-slam spring-assisted, center-guided, lugged pattern wafer check valve is designed to prevent water hammer and reverse flow. The lightweight compact design fits between mating flanges and meets API 594 face-to-face dimensions. The TLW Check Valve body design eliminates potential leak paths to the environment and is an easy-to-maintain check valve for applications involving liquids, gases, or steam. Tapped holes are provided in the body for lifting lugs to assist with installation (10" and larger sizes only).

FEATURES:

- API 594 Face-to-Face dimensions
- Threaded Lug Design
- ASME B16.5
- RF Wafer ends
- Spring-assisted silent closing
- Sizes 2" thru 24"
- Horizontal or vertical installation
- ASME Class 150 and 300
- Standard body materials:
 - A216 Grade WCB carbon steel
 - A351 CF8M stainless steel
- Stainless steel seat, disc & bushing
- Nitronic® 60 stem
- Inconel® X-750 Spring
- Seat Leakage per MSS SP-61
- Tapped holes in body for lifting lugs (10" size and larger)
- Axial flow
- Nozzle style
- Options:
 - 316 SS spring
 - Custom sizing - low flow
 - Soft seat
 - NACE (See DFT Catalog, page 41)

TLW™ Check Valve

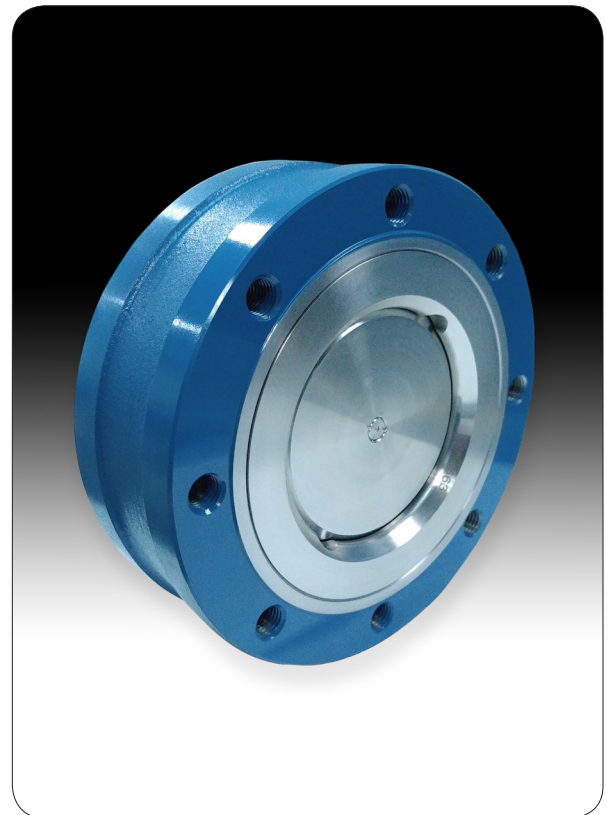
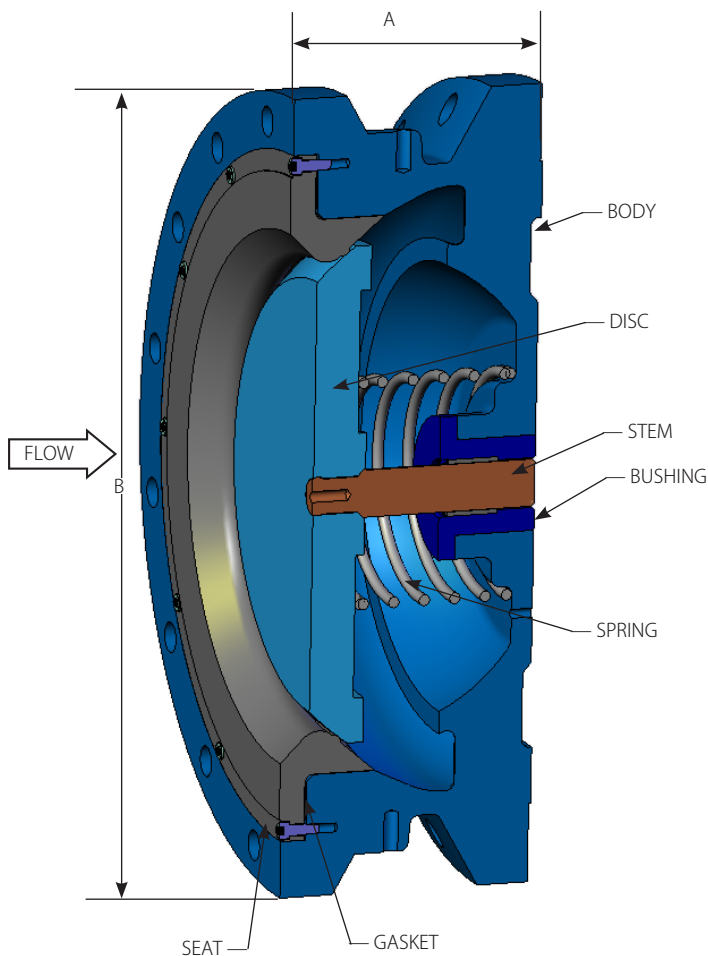

TLW™ Check Valve

Class	150 RF	300 RF	
2"	A	2.38	2.38
	B	6.00	6.50
	Weight	15	17
	Cv	120	120
	CP	0.65	0.65
2 1/2"	A	2.62	2.62
	B	7.00	7.50
	Weight	20	22
	Cv	205	205
	CP	0.69	0.69
3"	A	2.88	2.88
	B	7.50	8.25
	Weight	29	32
	Cv	260	260
	CP	0.63	0.63
4"	A	2.88	2.88
	B	9.00	10.00
	Weight	38	42
	Cv	430	430
	CP	0.59	0.59
6"	A	3.88	3.88
	B	11	12.50
	Weight	71	79
	Cv	825	825
	CP	0.59	0.59

Class	150 RF	300 RF	
8"	A	5.00	5.00
	B	13.50	15.00
	Weight	123	134
	Cv	1310	1310
	CP	0.55	0.55
10"	A	5.75	5.75
	B	16.00	17.50
	Weight	197	210
	Cv	1875	1875
	CP	0.53	0.53
12"	A	7.13	7.13
	B	19	20.50
	Weight	289	302
	Cv	2525	2525
	CP	0.53	0.53
14"	A	7.25	8.75
	B	21.00	23.00
	Weight	317	440
	Cv	2950	3275
	CP	0.55	0.55

Class	150 RF	300 RF	
16"	A	7.50	9.13
	B	23.5	25.5
	Weight	440	635
	Cv	*	*
	CP	0.50	0.50
18"	A	8.00	10.38
	B	25.00	30.88
	Weight	520	810
	Cv	*	*
	CP	0.55	0.55
20"	A	8.62	11.50
	B	27.50	30.50
	Weight	708	1012
	Cv	*	*
	CP	0.54	0.57
24"	A	8.75	12.50
	B	32	36
	Weight	945	1550
	Cv	*	*
	CP	0.52	0.57

* Consult DFT

MATERIALS OF CONSTRUCTION

COMPONENT	CARBON STEEL BODY	STAINLESS STEEL BODY
Body	A216 Grade WCB	A351 CF8M
Disc/Stem Assembly	316 SS/Nitronic® 60	316 SS/Nitronic® 60
Seat	316 SS	316 SS
Spring	Inconel® X-750	Inconel® X-750
Bushing	316 SS (1)	316 SS (1)
Gasket (2)	CFG (3)	CFG (3)

- Notes:**
1. Teflon® bushing on 14", 16", 18", 20" and 24".
 2. Gaskets only used on valves 10" and larger.
 3. 316/Graphite material.

All dimensions are in inches. Weights are in pounds. For metric measurements, visit www.dft-valves.com. CP: Cracking Pressure (psig)

Contact DFT for additional sizes/pressure classes.

WARNING: It is NOT recommended that any DFT check valve be used for dead end service.



DFT Inc., 140 Sheree Blvd., PO Box 566, Exton, PA 19341-0566
www.dft-valves.com
dft@dft-valves.com

Tel: 610-363-8903

Toll-Free: 800-206-4013

Fax: 610-524-9242

TLW 02.19.18